

MASON INDUSTRIES, Inc.

Manufacturers of Vibration Control Products

350 Rabro Drive 2101 W. Crescent Ave., Suite D
Hauppauge, NY 11788 Anaheim, CA 92801
631/348-0282 714/535-2727
FAX 631/348-0279 FAX 714/535-5738
Info@Mason-Ind.com Info@MasonAnaheim.com

JOB NAME _____
CUSTOMER _____
CUSTOMER P.O. _____
MASON M.I. _____
DWG. NO. _____

HCF

HOLE
CLEARANCE
FILLER

When there is excessive clearance between anchor bolts and equipment holes, the equipment has a tendency to shear off the anchor bolts during earthquakes or bomb blasts at accelerations as low as 0.2 g. The reason as explained in figure 1 is a velocity buildup because of sliding. What was initially analyzed as a static system becomes dynamic.

Type HCF hole clearance filler provides a quick solution as it fills this clearance created by practical tolerances, off center bolts or the extreme situation where holes are enlarged on the jobsite by drilling or burning.

HCF is a hand kneadable, non-rusting, steel reinforced epoxy that mixes in one minute to provide fast, permanent bonds to items made of ferrous and aluminum metals. After mixing, HCF has the consistency of clay and can be forced into the clearance with any tool similar to a putty knife or small scraper.

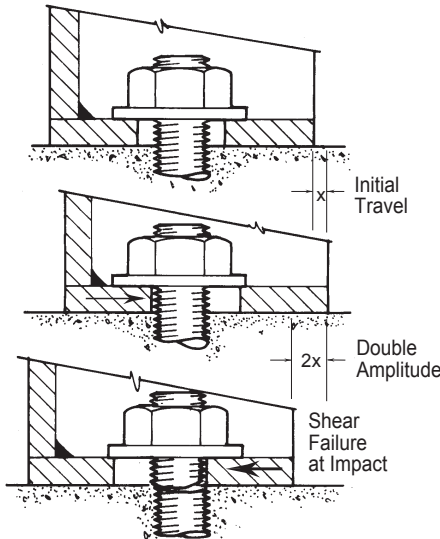

Figure 1- IMPACT SHEAR FAILURE

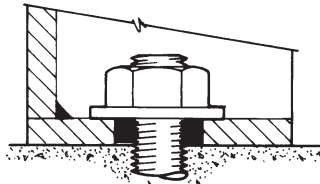

Figure 2- HCF REMEDY

PACKAGING:

HCF is packed in a clear plastic reusable tube with a plastic friction top.

COLOR: Black after cure.

HEALTH PRECAUTIONS:

HCF has been proven to be non-toxic and non-skin irritating when tested in accordance with the Federal Hazardous Substances Labeling Act. However HCF contains epoxy resins and amine which may cause irritation to sensitive skin. Wear protective plastic gloves to be safe and wash your hands and any exposed skin with soap and warm water after use.

In case of eye contact, flush with water and consult a physician. It may be harmful if swallowed. Keep out of the reach of children.

WARRANTY:

All recommendations, statements and technical data contained herein are based on tests we believe to be reliable and correct.

PERFORMANCE DATA:

WORKING LIFE	3 1/2 – 5 minutes
SHELF STABILITY	12 months min. @ 75°F 24°C
SHORE D HARDNESS	80 after 24 hours
TEMPERATURE LIMITATIONS	250°F 121°C continuous; 300°F 148°C intermittent
CHEMICAL RESISTANCE	Resistant to hydrocarbons, ketones, alcohols, esters, halocarbons, aqueous salt solutions and dilute acids and bases.
SHRINKAGE	Less than 1%
COMPRESSIVE STRENGTH	12,000 psi 844 kg/cm ²

APPLICATION INSTRUCTIONS:

SURFACE PREPARATION:

In order to achieve optimum adhesion, surfaces must be cleaned free of grease.

MIXING: Twist or cut off required amount. To mix, knead with fingers to a uniform color. If mixing is difficult, warm HCF to room temperature or slightly above.

FILLING: Shape into an oversized doughnut and force into equipment bolthole with a putty knife. Insert cap screw through washer and

doughnut and tighten before hardening begins (within two minutes of mixing). Strike off excess material, preferably with a tool wetted with clean water. HCF sets up in 30 minutes and the cure time is 24 hours.

