



MASON INDUSTRIES, Inc.

Manufacturers of Vibration Control Products

350 Rabro Drive
Hauppauge, NY 11788
631/348-0282
FAX 631/348-0279

2101 W. Crescent Ave., Suite D
Anaheim, CA 92801
714/535-2727
FAX 714/535-5738

Info@Mason-Ind.com • www.Mason-Ind.com

JOB NAME _____
CUSTOMER _____
CUSTOMER P.O. _____
MASON M. _____
DWG No. _____

30

1" 25mm Deflection
X, A, B, C, D & F
Spring Series
Hangers

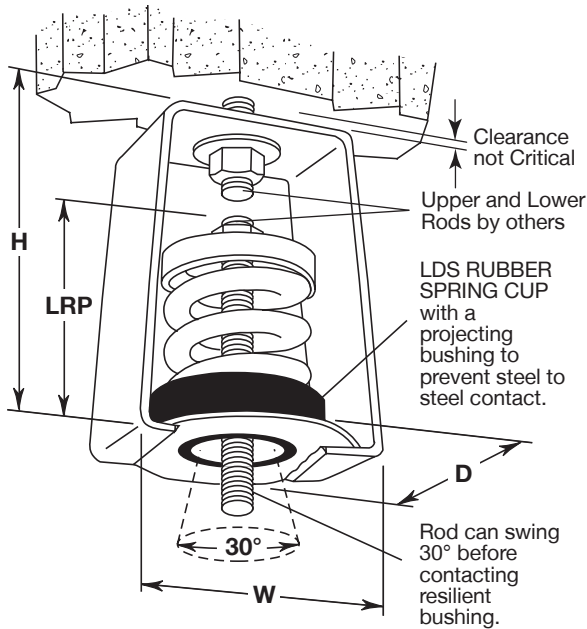

LDS stands for Low Dynamic Stiffness AASHTO Bridge Bearing Natural Rubber to minimize noise and vibration transmission. Maximum Dynamic Stiffness is 1.4.

TYPE 30 RATINGS

Type and Size	Rated Capacity (lbs) (kg)		Rated Deflection (in) (mm)		Spring Constant (lbs/in) (kg/mm)		Spring Color
30-X-12	12	5	1.25	32	10	0.18	Orange
30-X-23	23	10	1.30	33	18	0.30	Brown
30-X-33	33	15	1.10	28	30	0.54	Copper
30-X-54	54	24	1.20	30	45	0.80	White
30-X-76	76	34	1.00	25	73	1.36	Black
30-X-113	113	51	1.00	25	113	2.04	Brass
30-X-130	130	59	1.00	25	130	2.36	Purple
30-X-175	175	79	1.00	25	175	3.16	Silver
30-X-210	210	95	1.00	25	210	3.80	Blue
30-A-12	12	5	1.00	25	12	0.20	Copper
30-A-18	18	8	1.00	25	18	0.32	Gray
30-A-25	25	11	1.00	25	25	0.44	Orange
30-A-41	41	19	1.18	30	35	0.63	Pink
30-A-56	56	25	1.14	30	49	0.83	Black
30-A-73	73	33	1.06	27	69	1.22	Tan
30-A-95	95	43	1.01	26	94	1.65	Green
30-B-138	138	63	1.32	34	105	1.85	White
30-B-222	222	101	1.16	29	191	3.48	Blue
30-B-278	278	126	1.09	28	255	4.50	Purple
30-B-336	336	152	1.00	25	336	6.08	Silver
30-B-410	410	186	1.07	27	385	6.89	Black
30-B-540	540	245	1.00	25	540	9.80	Yellow
30-C-630	630	286	1.13	29	558	9.86	Gray
30-C-800	800	363	1.00	25	800	14.52	Orange
30-C-1010	1010	458	1.10	28	920	16.36	Green
30-C-1265	1265	574	1.00	25	1265	22.96	Red
30-D-1575	1575	714	1.23	31	1280	23.03	Pink
30-D-2150	2150	975	1.03	26	2095	37.50	Purple
30-F-2760	2760	1252	1.00	25	2760	50.08	Silver

TYPE 30 DIMENSIONS

Type and Size Range	D - Depth		H - Height		W - Width		LRP		MRD	
	(in)	(mm)	(in)	(mm)	(in)	(mm)	(in)	(mm)	(in)	(mm)
30-X-12-210	21/2	64	41/4	108	27/8	73	31/2	89	3/8	10
30-A-12-25	23/4	70	53/4	146	31/4	83	31/2	89	5/8	16
30-A-41-95	23/4	70	53/4	146	31/4	83	4	102	5/8	16
30-B-138-540	4	102	71/4	184	43/4	121	41/4	108	5/8	16
30-C-630-1265	4	102	83/4	222	51/4	132	5	127	3/4	19
30-D-1575-2150	43/4	121	121/2	318	53/4	146	7	178	7/8	22
30-F-2760	6	152	12	305	61/4	159	7	178	7/8	22

LRP - Lower Rod Diameter
MRD - Maximum Rod Diameter

All springs have additional travel to solid equal to 50% of the Rated Deflection.

PLAN VIEW OF HANGER LOCATIONS

TAG: _____
UNIT: _____

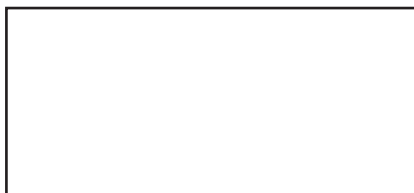

SPECIFIED DEFLECTION

1:	6:
2:	7:
3:	8:
4:	9:
5:	10:
Sets Required:	