



**MASON INDUSTRIES, Inc.**  
Manufacturers of Vibration Control Products

350 Rabro Drive  
Hauppauge, NY 11788  
631/348-0282  
FAX 631/348-0279  
Info@Mason-Ind.com  
www.Mason-Ind.com

2101 W. Crescent Ave., Suite D  
Anaheim, CA 92801  
714/535-2727  
FAX 714/535-5738  
Info@MasonAnaheim.com  
www.MasonAnaheim.com

**SPRING  
JACK-UP MOUNTS  
for CONCRETE  
FLOATING FLOORS**

TYPE  
**FS**

DATA SHEET DS-55-3

**POSITION 1 FLOOR IN POURED POSITION**

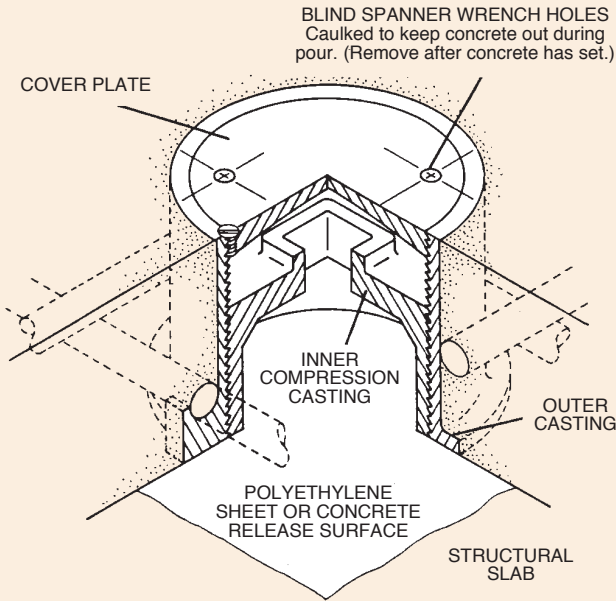

**POSITION 2 SPRING & NEOPRENE CUP INSTALLED**

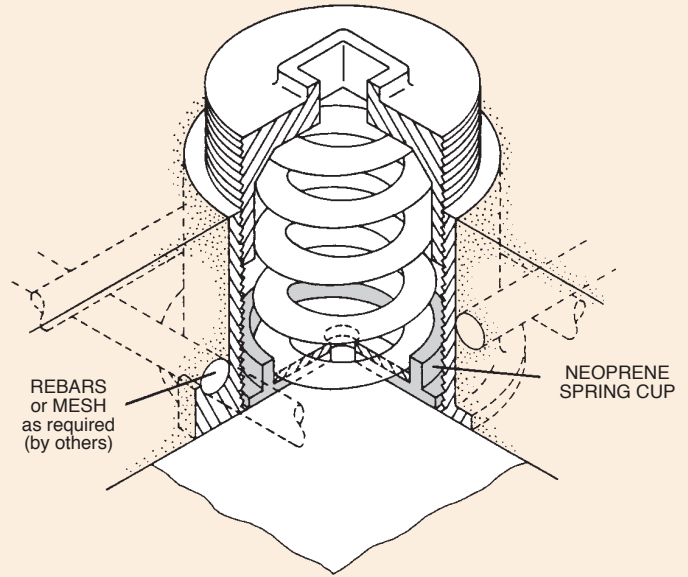

**POSITION 3 FLOOR IN RAISED POSITION WITH COVER PLATE INSTALLED**

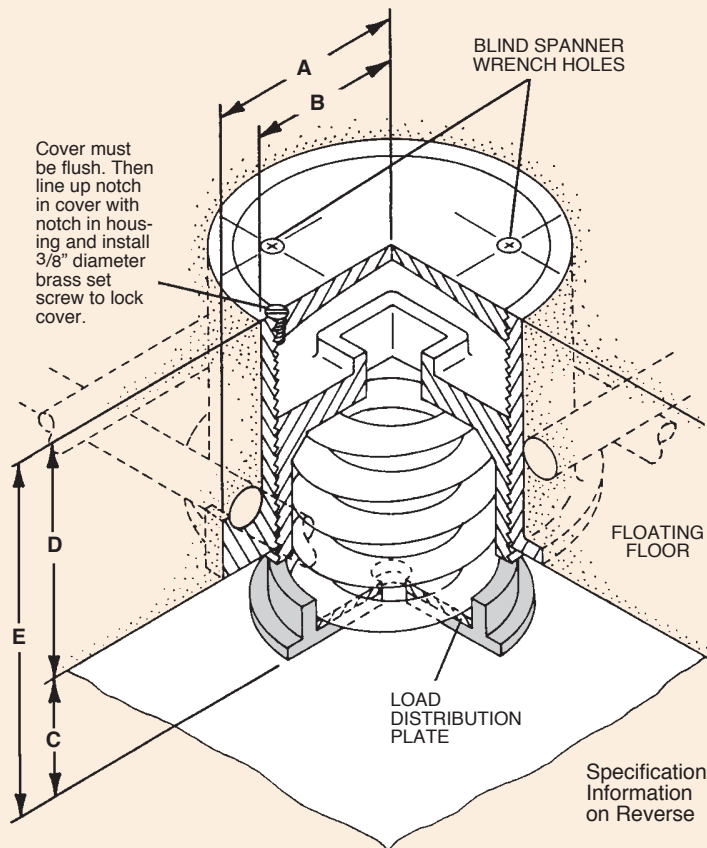

Illustrated housing is for 4"(100mm) thick floating floors. Other outside configurations available for 3"(75mm), 5"(125mm) and 6"(150mm) thick floating floors as required.

<sup>†</sup>Requires 2"(50mm) minimum Air Gap

**TYPE FS RATINGS**

Size	Rated Capacity (lbs) (kgs)	Rated Defl (in) (mm)	Mount Constant (lb/in)(kg/mm)	Spring Color/Stripe
FS-B-450	450 <b>204</b>	1.31 <b>33</b>	344 <b>6.2</b>	Red
FS-B-750	750 <b>340</b>	1.12 <b>28</b>	670 <b>12.1</b>	White
FS-B-1000	1000 <b>454</b>	1.00 <b>25</b>	1000 <b>18.2</b>	Blue
FS-C-1000	1000 <b>454</b>	1.00 <b>25</b>	1000 <b>18.2</b>	Black
FS-C-1350	1350 <b>612</b>	1.00 <b>25</b>	1350 <b>24.5</b>	Yellow
FS-C-1750	1750 <b>794</b>	1.00 <b>25</b>	1750 <b>31.8</b>	Black*
FS-C-2100	2100 <b>953</b>	1.00 <b>25</b>	2100 <b>38.1</b>	Yellow*
FS-C-2385	2385 <b>1082</b>	1.00 <b>25</b>	2385 <b>43.3</b>	Yellow**
FS-C-2650	2650 <b>1202</b>	1.00 <b>25</b>	2650 <b>48.1</b>	Red*
FS-C-2935	2935 <b>1331</b>	1.00 <b>25</b>	2935 <b>53.2</b>	Red**
FS-B2-450 <sup>†</sup>	450 <b>204</b>	2.00 <b>51</b>	224 <b>4.0</b>	Tan
FS-B2-680 <sup>†</sup>	680 <b>308</b>	2.00 <b>51</b>	340 <b>6.0</b>	Gray
FS-C2-610 <sup>†</sup>	610 <b>277</b>	2.00 <b>51</b>	305 <b>5.4</b>	Green
FS-C2-880 <sup>†</sup>	880 <b>399</b>	2.00 <b>51</b>	440 <b>7.8</b>	Gray
FS-C2-1210 <sup>†</sup>	1210 <b>549</b>	2.00 <b>51</b>	605 <b>10.8</b>	Silver
FS-C2-1540 <sup>†</sup>	1540 <b>699</b>	2.00 <b>51</b>	770 <b>13.7</b>	Gray*
FS-C2-1870 <sup>†</sup>	1870 <b>848</b>	2.00 <b>51</b>	935 <b>16.6</b>	Silver*

\*with RED inner spring \*\*with GREEN inner spring

<sup>†</sup>Published ratings allow minimum 25% additional travel to solid. For a full 50% specified minimum use the following ratings:

Size	Derated Capacity (lbs) (kgs)	Defl (in) (mm)	Size	Derated Capacity (lbs) (kgs)	Defl (in) (mm)
B2-450	410 <b>186</b>	1.83 <b>46</b>	C2-1210	1010 <b>458</b>	1.67 <b>42</b>
B2-680	565 <b>256</b>	1.66 <b>42</b>	C2-1540	1285 <b>583</b>	1.67 <b>42</b>
C2-880	800 <b>363</b>	1.82 <b>46</b>	C2-1870	1560 <b>708</b>	1.67 <b>42</b>

**TYPE FS DIMENSIONS**

Type & Size	Housing Dimensions A B	C Air Gap	D Floor Thickness	E Overall Height
FS-B & B2	23/4" 2" <b>70mm 50mm</b>	Most Common 1" or 2" <b>25 or 50mm</b>	Minimum 3" <b>75mm<sup>†</sup></b> Most Common 4" <b>100mm</b>	Air Gap Plus Floor Thickness
FS-C & C2	31/4" 21/2" <b>83mm 65mm</b>	Occasionally 3" or 4" <b>75 or 100 mm</b>	Occasionally 6" thru 12" <b>150 or 300mm</b>	

## SPECIFICATION INFORMATION

### A. Scope

Isolate floating floor from building structure by means of steel spring jack-up isolators and perimeter isolation board.

### B. Materials

1. Plastic sheeting: 6 mil(0.15mm)
2. Isolators: Castings or weldments consisting of an outer housing with internal threads and an inner housing with external threads. Outer housing shall have a removable cover plate, lifting flange, and lugs to position the steel reinforcement. The inner housing forms a protective cover over the spring element and shall be designed for spring adjustment. Springs shall be free standing, laterally stable and seated in a minimum 1/4"(6mm) thick neoprene acoustical cup. Spring deflection shall be a minimum of \_\_\_\_\_ inches under the combined dead and live load. Air gap shall be \_\_\_\_\_ inches.
3. Perimeter Isolation Board: 3/4"(20mm) thickness 10 lb. fiberglass or 1/2"(12mm) neoprene sponge.
4. Caulking Compound: Non-hardening, non-drying and non bleeding.
5. Floating Floor Drains: Cast iron pipe buckets with cast iron grills and large flanges to cover structural openings complete with waterproofing clamping ring. Upper member shall float with floating floor and sound leakage prevented by an interlocking water trap. Drains shall have weep holes where indicated on drawings.
6. Riser Seals: Steel cylinders containing neoprene sponge seals for both structural and floating floors.

### C. Floor system adjustment procedure

1. Structural floor must be level, at mount locations, to specifications for upper surface of floating floor as mountings are used as screed points. Smoothness at mount locations plus or minus 0.03"(0.7mm).
2. Concrete perimeter forms must be set where required.
3. Cement perimeter material to wall, forms, around columns, etc. as shown on drawings and details.
4. Snap chalk lines showing mounting locations on structural floor. Spray paint or crayon intersections for clearer visibility through 6 mil(0.15mm) polyethylene sheeting.
5. Lay transparent polyethylene sheeting over entire floor area, lapping up and over perimeter isolation material and tape up to maintain position. Overlap sheeting one foot to increase width, where required and tape all seams.
6. Before placing castings, check to see if threads are greased and inner casting is flush with the bottom of the outer casting as on the Position 1 illustration. If not, turn casting to make it flush.
7. Place castings on maximum 48"(1200mm) centers in locations marked in Step 4 and in accordance with layout drawings.
8. Install reinforcing as shown on Mason or contract drawings.

9. Pour concrete to required thickness and finish flush with tops of floor mounts in a single pour. Work concrete around mountings and reinforcement to eliminate voids and entrapped air. Exercise caution to avoid shifting or lifting of mountings.

10. After concrete is fully cured and ready for lift, prepare each casting for spring installation as follow:

- A. Remove putty from 3/8" brass cover set screw and spanner holes. Remove set screw and store carefully.
- B. Unscrew cover plate by turning counter clockwise with 1" spanner wrench.
- C. Remove inner casting by turning counter clockwise with 1" square "T" wrench.

11. Install neoprene spring cup and proper spring in each locations. Replace inner casting as shown on the Position 2 illustration. Turn inner compression casting until it bears against top of spring.

12. Using square "T" wrench, take four clockwise turns on every inner casting. Work can proceed at one location at a time or with a gang of workers working simultaneously. Step 12 must be completed before proceeding to Step 13.

13. Take two additional clockwise turns on each inner casting.

14. Repeat Step 13 until floor is lifted to required elevation. Approximately eight turns are needed to compress the spring one inch and after springs are at design deflection, each additional eight turns lifts the floor one inch.

15. Install cover plate flush with top of floor and replace brass set screw to lock cover plate in position (see Position 3 illustration). This completes the spring adjustment procedure.

16. Caulk all around perimeter and penetrations as shown on drawing and details.

### D. Submittals

1. Isolator layout drawings.
2. Isolator details.
3. Load and deflection curves of all isolators. (Steel spring mountings have dynamic frequencies which can be calculated from the deflection so that dynamic frequency tests are never run. To the best of our knowledge, no one has run acoustical tests on this type of installation because the steel springs function very close to the theoretical predictions.)
4. Drain details
5. Perimeter board details
6. Installation Procedure

### E. Manufacturer

1. The setting of all isolation material and raising of the floor shall be performed by or under the supervision of the isolation manufacturer.
2. Subject to compliance with the specifications the following products are approved for use. Type FS Jack-up Mountings, AFG-10 Perimeter Board, CFD Floor Drains, SPS Spool Pipe Seals, Type CC-75 and CC-50 Caulking Compounds, all as manufactured by Mason Industries Inc.