



MASON INDUSTRIES, Inc.

Manufacturers of Vibration Control Products

350 Rabro Drive
Hauppauge, NY 11788
631/348-0282
FAX 631/348-0279
Info@Mason-Ind.com • www.Mason-Ind.com

2101 W. Crescent Ave., Suite D
Anaheim, CA 92801
714/535-2727
FAX 714/535-5738

JOB NAME _____
CUSTOMER _____
CUSTOMER P.O. _____
MASON M. _____
DWG No. _____

DP
DASH POT
VISCOUS FLUID
DAMPERS

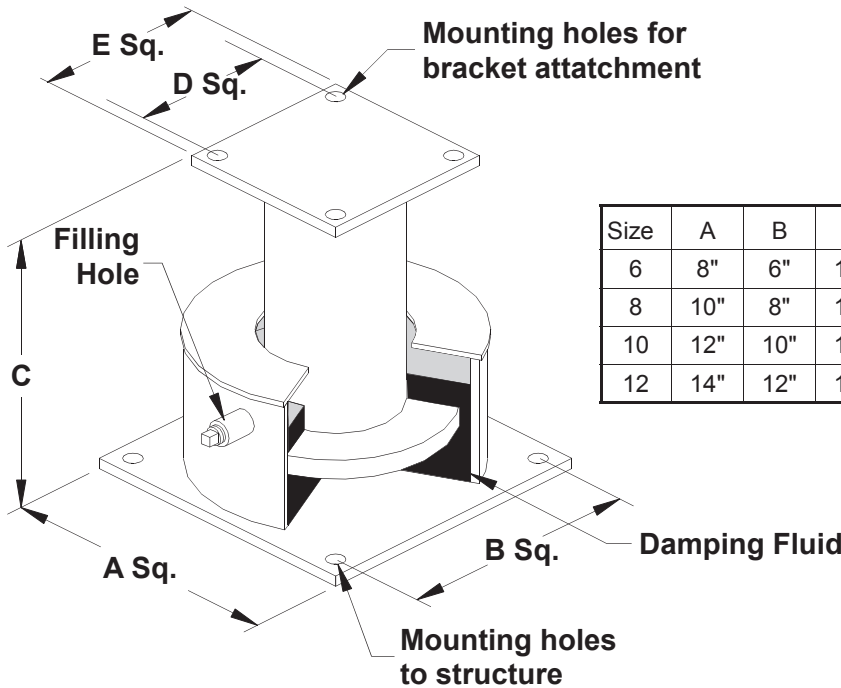

Size	A	B	C	D	E	Damping-Constant (C)
6	8"	6"	12"	2 1/2"	4"	5 - 10#/In/Sec
8	10"	8"	12"	3"	4 1/2"	10 - 55#/In/Sec
10	12"	10"	12"	5"	6 1/2"	60 - 90#/In/Sec
12	14"	12"	12"	7"	8 1/2"	110 - 140#/In/Sec

1. Standard dampers have 6, 8, 10 & 12 inch cylinder diameters.
2. Piston diameters are designed by Mason Industries based on system damping requirements.
3. The standard damping fluid has a viscosity of 30,000 cs. Other fluids may be used with a maximum viscosity of 100,000 cs. Silicone fluids insure viscosity stability thru the broadest possible temperature change.
4. Other sizes are custom designed as required.

PLAN VIEW OF MOUNT LOCATIONS

TAG: _____
UNIT: _____

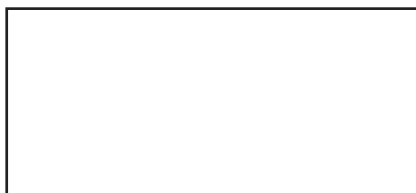

1:	6:
2:	7:
3:	8:
4:	9:
5:	10:
Sets Required:	