



MASON INDUSTRIES, Inc.

Manufacturers of Vibration Control Products

350 Rabro Drive
Hauppauge, NY 11788
631/348-0282
FAX 631/348-0279

2101 W. Crescent Ave., Suite D
Anaheim, CA 92801
714/535-2727
FAX 714/535-5738

Info@Mason-Ind.com • www.Mason-Ind.com

TYPE

WBI & WBD

THRUST RESTRAINTS

DATA SHEET DS-207S-2.1

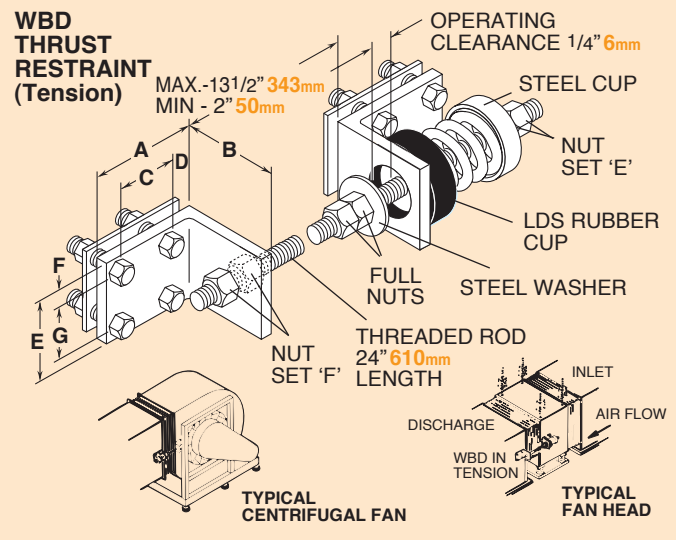
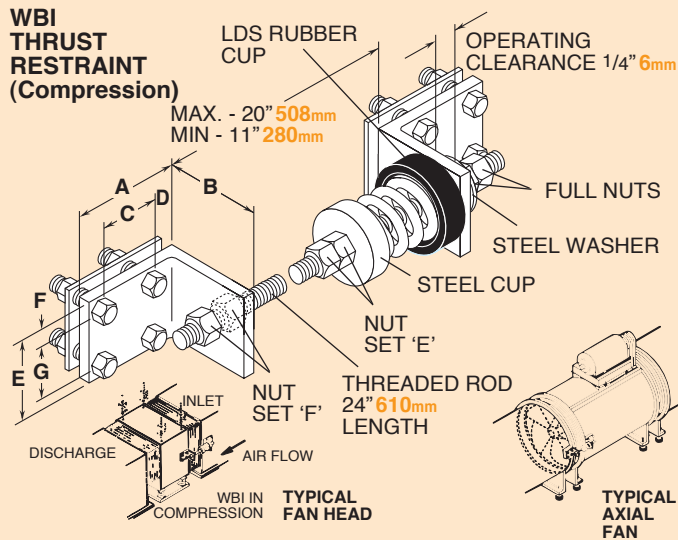

Fans Heads are cabinets containing a fan and motor and no accessories such as coils or filters. They can develop extremely high thrusts that are equal to the suction area multiplied by the negative head plus the positive pressure multiplied by the discharge area. These forces act horizontally, opposite to the airflow and about halfway up the cabinet. Since fan heads are light and narrow they tend to shift and overturn with damage to the flexible connections or to the units themselves.

Thrust restraints are recommended for all fan heads and for axial or centrifugal fans when the air thrust exceeds 10% of the equipment weight.

Type WBI and WBD Thrust Restraints are precompressed assemblies designed to withstand these forces and allow only minor motion. The WBI is considered standard and used in compression across the inlet flexible connection on both sides. The WBD design is used in tension across the discharge when WBI is impractical. We furnish all parts except those noted "by others".

One end of either the WBI or WBD Assembly must be attached to the unit. The other end is normally attached to the ductwork or adjacent section, but when this becomes difficult it can be attached to a ceiling or floor stanchion fabricated for this purpose.

WBI Units can be converted to WBD by reversing the spring assembly on the angle as illustrated.

TYPE WBI & WBD DIMENSIONS (inches)

Type	Size	A	B	C	D	E	F	G	Threaded Rod	Max Restraint (lbs/Pair)	Max Fan Head Inlet* (ft sq)	Max Axial Fan Discharge Area** (ft sq)	Rated Capacity (lbs)	Rated Defl (in)	Spring Constant (lbs/in)	Spring Color/Stripe
WBI-	A-310	3 1/2	3	1 3/4	1 1/4	3	1/2	2	1/2-13NC	620	26.00	20.00	310	1.00	310	Yellow
	B-750	4	3 1/2	2 1/4	1 1/4	3	1/2	2	5/8-11NC	1500	64.00	47.00	750	1.12	670	White
	B-1000	4	3 1/2	2 1/4	1 1/4	3	1/2	2	5/8-11NC	2000	86.00	64.00	1000	1.00	1000	Blue
WBD-	B2-290	4	3 1/2	2 1/4	1 1/4	3	1/2	2	5/8-11NC	580	25.00	19.00	290	2.00	144	Blue
	B2-450	4	3 1/2	2 1/4	1 1/4	3	1/2	2	5/8-11NC	900	38.00	29.00	450	2.00	224	Tan
	B2-680	4	3 1/2	2 1/4	1 1/4	3	1/2	2	5/8-11NC	1360	58.00	44.00	680	2.00	340	Gray
	129	6	6	3 7/8	1 1/2	5	5/8	3 3/4	5/8-11NC	1040	45.00	33.00	520	3.25	162	Green
	153	8	7	5	2 1/4	6 1/2	1	4 1/2	5/8-11NC	1060	45.00	34.00	530	4.38	120	Green

*Based on 6" pressure differential across unit with 4.5" negative pressure

**Based on 6" pressure differential

TYPE WBI & WBD DIMENSIONS (mm)

Type	Size	A	B	C	D	E	F	G	Threaded Rod	Max Restraint (kgs/Pair)	Max Fan Head Inlet* (m2)	Max Axial Fan Discharge Area** (m2)	Rated Capacity (kgs)	Rated Defl (mm)	Spring Constant (kg/cm)	Spring Color/Stripe
WBI-	A-310	89	75	45	32	75	13	50	1/2-13NC	280	2.4	1.8	140	25	5.6	Yellow
	B-750	100	89	57	32	75	13	50	5/8-11NC	680	6.0	4.4	340	28	12.1	White
	B-1000	100	89	57	32	75	13	50	5/8-11NC	910	8.0	6.0	455	25	18.2	Blue
WBD-	B2-290	100	89	57	32	75	13	50	5/8-11NC	265	2.3	1.7	130	50	2.6	Blue
	B2-450	100	89	57	32	75	13	50	5/8-11NC	410	3.5	2.7	205	50	4.1	Tan
	B2-680	100	89	57	32	75	13	50	5/8-11NC	620	5.3	4.1	310	50	6.2	Gray
	129	150	150	98	38	125	16	95	5/8-11NC	470	4.2	3.1	235	83	2.8	Green
	153	200	175	125	57	165	25	114	5/8-11NC	480	4.2	3.2	240	110	2.2	Green

*Based on 152mm pressure differential across unit with 115mm negative pressure

**Based on 150mm pressure differential

EXAMPLES OF CALCULATIONS USED TO DETERMINE NEED FOR THRUST RESTRAINTS

1" Water Pressure = 5.2 lbs/ft²

EQUIPMENT TYPE	SIZE (in)	INLET AREA (ft ²)	OUTLET AREA (ft ²)	WEIGHT (lbs)	PRESSURE DIFFERENTIAL (inches of water)	ASSUMPTION	FORCE (lbs) Equals		Thrust Restraints are Required when Thrust Force Exceeds 10% of Equipment Weight	RESTRAINTS Number Size
							Water Pressure x 5.2' x Area (in)	(lbs/ft ²)		
Fan Head	Typical	73	20	2600	4	40% Inlet 60% Outlet	(.4x4) x 5.2 x 73 = 607 (.6x4) x 5.2 x 20 = 249 Total Force 856	856 2600 = 33%	2	B-750
Axial Blower	60	19.6	19.6	1553	3	All Discharge	3 x 5.2 x 19.6 = 306	306 1553 = 20%	2	A-310
Double Inlet Class 1 Fan	49	Not Considered	24.8	4000 with Motor & Steel Base	3	All Discharge	3 x 5.2 x 24.8 = 387	387 4000 = 9.7%	None	Required

EXAMPLES OF CALCULATIONS USED TO DETERMINE NEED FOR THRUST RESTRAINTS (metric)

125mm Water Pressure = 249 N/m²

EQUIPMENT TYPE	SIZE (m)	INLET AREA (m ²)	OUTLET AREA (m ²)	WEIGHT (kgs)	PRESSURE DIFFERENTIAL (N/m ²)	ASSUMPTION	FORCE (N) Equals		Thrust Restraints are Required when Thrust Force Exceeds 10% of Equipment Weight	RESTRAINTS Number Size
							Water Pressure x 6.8' x Area (N/m ²)	(kg/cm ²)		
Fan Head	Typical	6.8	1.85	1179	996	40% Inlet 60% Outlet	996 x 6.8 x 0.4 = 2709N 996 x 1.85 x 0.6 = 1106N Total Force = 3815 N	389 kg = 33% 1179 000000	2	B-750
Axial Blower	1.5	1.82	1.82	704	747	All Discharge	747 x 1.82 = 1360 N (138 kg)	138 kg = 20% 704 000000	2	A-310
Double Inlet Class 1 Fan	1.25	Not Considered	2.3	1814 with Motor & Steel Base	747	All Discharge	747 x 2.3 = 1718 N (175 kg)	175 kg = 9.7% 1814 000000	None	Required

INSTALLATION INSTRUCTIONS

- 1) Check with air handling unit manufacturer to establish the structural integrity of the unit and to determine their recommendation as to the bolting position.
- 2) Install Unit on Mounting or suspend from Hangers.
- 3) Bolt thrust assembly angle brackets with back-up plates to fan cabinet on the centerline of the inlet (approximately halfway up the unit). Bolt second angle bracket with back-up plates to the plenum or coil section as shown. If overall length is more than needed, loosen nut set "F", slide angle on threaded rod and retighten.
- 4) Turn unit on.
 - a) If the operating clearance between angle and washer exceeds 1/4" 6mm, turn nut "E" clockwise (to load spring) two turns at a time on assembly until clearance is reduced 1/4" 6mm.
 - b) If the operating clearance between angle and washer is less than 1/4" 6mm, turn nut "E" counterclockwise (to unload spring) two turns at a time on each assembly, until clearance is 1/4" 6mm.
- 5) When unit is shut down, the 1/4" 6mm operating clearance will disappear and reappear when operation is renewed.

HORIZONTAL THRUST RESTRAINTS

It is not unusual to encounter problems where the horizontal combined air thrust exceeds 10% of the equipment weight. If the spring columns alone resist a 10% force, they will lean over about 12% of the rated deflection. This is the recommended maximum.

When the thrust is higher, the best solution is adding mass to bring the ratio back down to 10%. If adding mass is impractical, horizontal restraints are another possibility. This is particularly true of fan heads, but high pressure axial and centrifugal fans may present the same problem. The equipment may be hung or floor mounted. Our horizontal restraint is a modified spring hanger with a precompression adjustment to limit movement when the system starts and stops and the air pressure builds up or dies off, as explained in the specification.

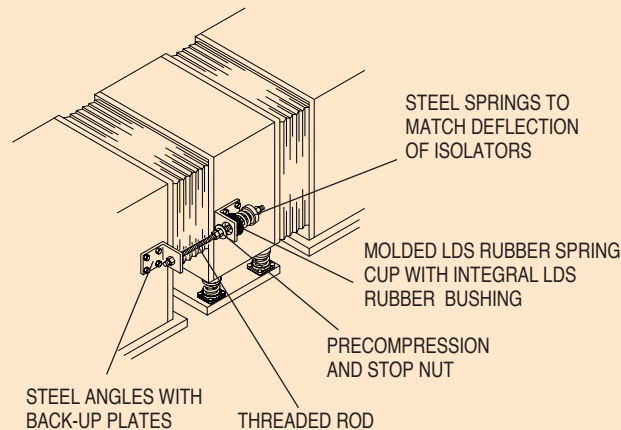

SPECIFICATION

When total air thrust exceeds 10% of the isolated weight, floor mounted or suspended air handling equipment shall be protected against excessive displacement by the use of horizontal thrust restraints. The restraint shall consist of a modified Specification B spring mounting. Restraint springs shall have the same deflection as the isolator springs. The assembly shall be preset at the factory and

fine tuned in the field to allow for a maximum of 1/4" 6mm movement from stop to maximum thrust. The assemblies shall be furnished with rod and angle brackets for attachment to both the equipment and duct work or the equipment and the structure. Restraints shall be attached at the center line of thrust and symmetrically on both sides of the unit. Horizontal thrust restraints shall be WB as manufactured by Mason Industries, Inc.