



MASON INDUSTRIES, Inc.

Manufacturers of Vibration Control Products
 350 Rabro Drive 2101 W. Crescent Ave., Suite D
 Hauppauge, NY 11788 Anaheim, CA 92801
 631/348-0282 714/535-2727
 FAX 631/348-0279 FAX 714/535-5738
 Info@Mason-Ind.com Info@MasonAnaheim.com
 www.Mason-Ind.com

JOB NAME _____
 CUSTOMER _____
 CUSTOMER P.O. _____
 MASON M.I. _____
 DWG. NO. _____

451 AS

EXPANSION
 JOINT
 AIR SPRING

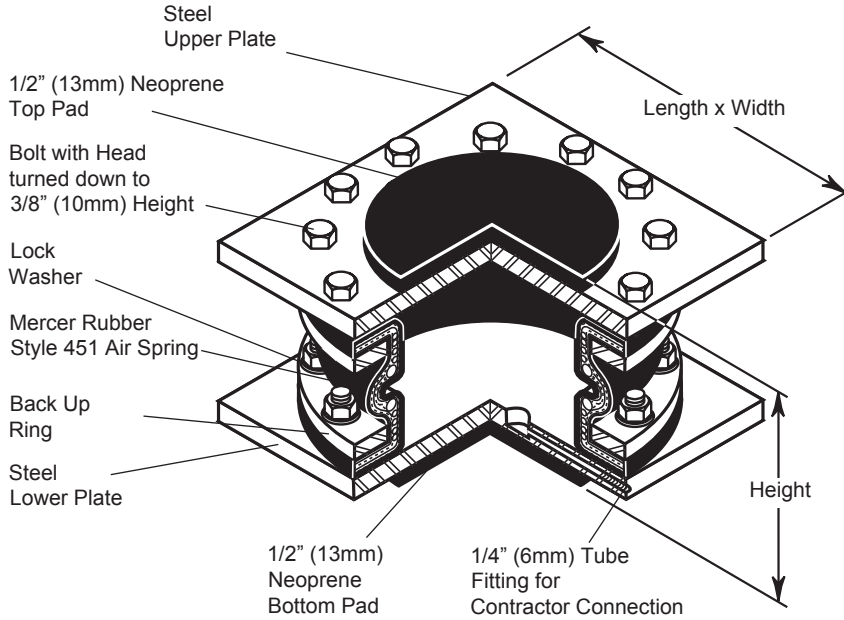

AIR SPRING LEVELING VALVE

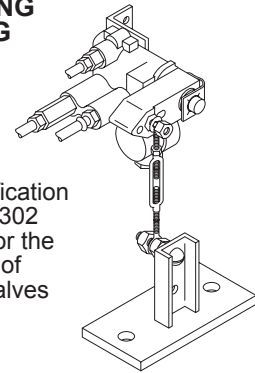

See Certification
 Sheets S-302
 & S-304 for the
 two types of
 leveling valves

All Air Spring Systems
 must be installed with
 Leveling Valves and
 Air Supply Systems.

TYPE 451 AS LOAD RATINGS AND DIMENSIONS

Size	Load Capacity (lbs)				L x W (in) x (in)	Height (in)
	@ 25 psi	@ 50psi	@ 100 psi	@ 150 psi		
451AS-10	1965	3930	7860	11790	16 x 16	10 1/2
451AS-12	2830	5660	11320	16980	19 x 19	10 1/2
451AS-14	3850	7700	15400	23100	21 x 21	10 1/2
451AS-16	5030	10060	20120	30180	24 x 24	10 1/2
451AS-18	6360	12720	25440	38160	25 x 25	10 1/2
451AS-20	7850	15700	31400	47100	28 x 28	10 1/2
451AS-24	11310	22620	45240	67860	33 x 33	12 1/2
451AS-30	17670	35340	70680	106020	40 x 40	12 1/2
451AS-36	25450	50900	101800	152700	47 x 47	12 1/2

TYPE 451 AS LOAD RATINGS AND DIMENSIONS (METRIC)

Size	Load Capacity (kg)				L x W (mm) x (mm)	Height (mm)
	@ 172 kpa	@ 345 kpa	@ 690 kpa	@ 1034 kpa		
451AS-10	891	1783	3565	5348	406 x 406	267
451AS-12	1284	2567	5135	7702	483 x 483	267
451AS-14	1746	3493	6985	10478	533 x 533	267
451AS-16	2282	4563	9126	13689	610 x 610	267
451AS-18	2885	5770	11539	17309	635 x 635	267
451AS-20	3561	7121	14243	21364	711 x 711	267
451AS-24	5130	10260	20521	30781	838 x 838	318
451AS-30	8015	16030	32060	48090	1016 x 1016	318
451AS-36	11544	23088	46176	69264	1194 x 1194	318

PLAN VIEW OF MOUNT LOCATIONS

TAG : _____

UNIT : _____

1 :	6 :
2 :	7 :
3 :	8 :
4 :	9 :
5 :	10 :
Sets Required:	

