



MASON INDUSTRIES, Inc.

Manufacturers of Vibration Control Products
 350 Rabro Drive Hauppauge, NY 11788
 631/348-0282 FAX 631/348-0279
 Info@Mason-Ind.com
 2101 W. Crescent Ave., Suite D Anaheim, CA 92801
 714/535-2727 FAX 714/535-5738
 Info@MasonAnaheim.com
 www.Mason-Ind.com

JOB NAME _____
 CUSTOMER _____
 CUSTOMER P.O. _____
 MASON M.I. _____
 DWG. NO. _____

LEVELING VALVE AIR SPRING ASSEMBLY

Air Springs must be installed with Leveling Valves and Air Supply Systems.

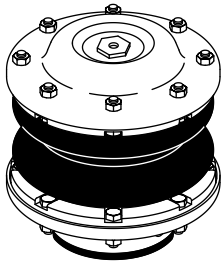

MT Twin Sphere Air Spring

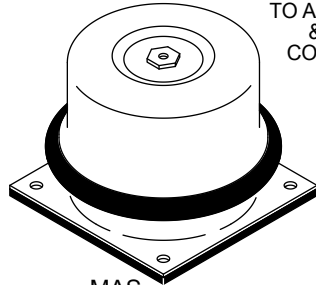

MAS Rolling Lobe Air Spring

MICRO LEVELING SYSTEM VALVE

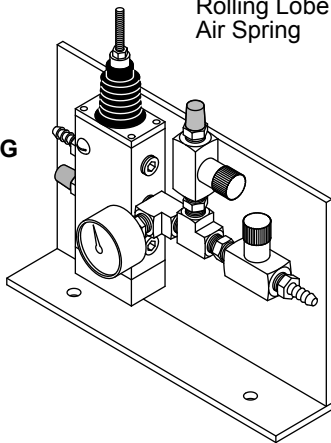

TO AIR SUPPLY & EXHAUST CONNECTION
1/4" NPT

AIR SUPPLY (BY OTHERS)
100 psi (7 kg/cm²)

EXHAUST TO ATMOSPHERE

EQUIPMENT MOUNTING BRACKET

AIR SUPPLY AND EXHAUST LEVER (neutral when level)

CL OF ROTARY VALVE MECHANISM

SELF LOCKING NUT

LENGTHEN BUCKLE TO INCREASE HEIGHT. ACCURACY ±1/8" (3mm)

If equipment loses elevation by 1/8" (3mm), Valve supplies air.

If equipment lifts 1/8" (3mm), Valve exhausts air.

SELF LOCKING NUT

FLOOR MOUNTING PLATE

See Cert Sheets S-300, S-301, S-303 S-278 & S-279 For Additional Information

