



**MASON INDUSTRIES, Inc.**  
Manufacturers of Vibration Control Products

350 Rabro Drive  
Hauppauge, NY 11788  
631/348-0282  
FAX 631/348-0279

2101 W. Crescent Ave., Suite D  
Anaheim, CA 92801  
714/535-2727  
FAX 714/535-5738

Info@Mason-Ind.com • www.Mason-Ind.com

## PIPE RISER SUPPORT SYSTEMS

Steve Fey,  
Senior Field Application Engineer

Bulletin RISER-112

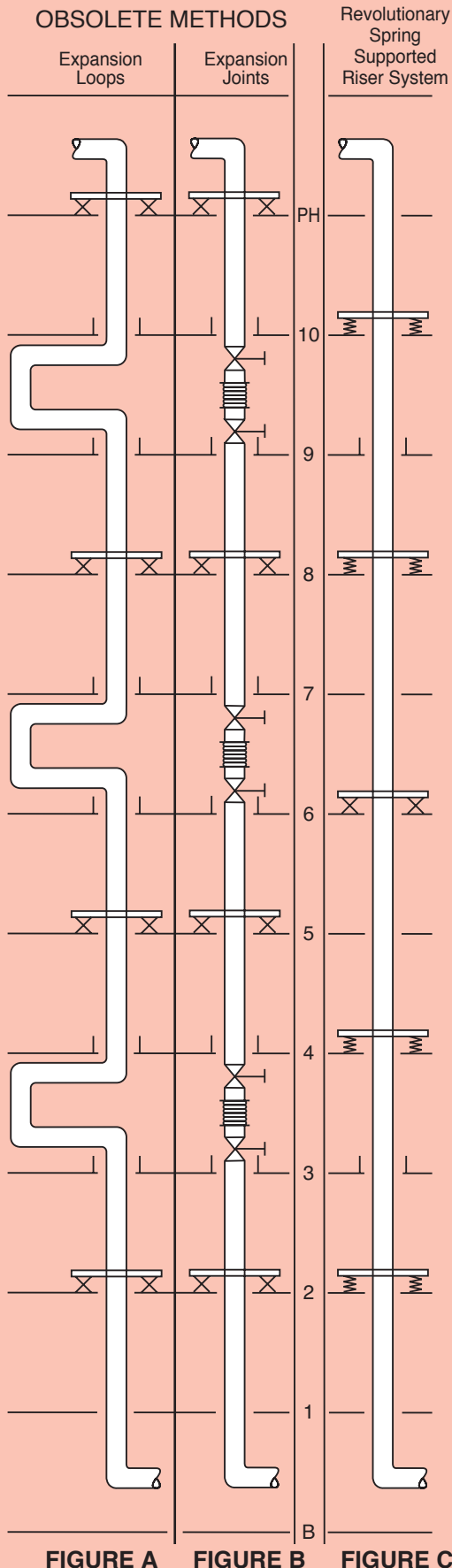

Supporting pipe risers subject to thermal expansion and contraction in hi-rise HVAC Systems has presented tremendous problems to the Design Engineer. Standard carbon steel piping expands or contracts at a rate of 0.8" (20 mm) per 100ft (30.5 m) per 100°F (37.8°C), so pipe growth of 5" (127 mm) in tall hi-rise structures is common.

Solutions for accommodating this movement include horizontal expansion loops or incorporating expansion joints and several anchor points. These methods may be adequate, but there are many negative features.

The use of horizontal expansion loops (Figure A) can result in the need for higher horse power pumps to overcome the additional friction and directional change in the horizontal runs. The additional horizontal piping adds to material and labor costs and may reduce the amount of rentable space as the pipe leaves and returns to the riser chase.

Prior to the introduction of stainless steel or rubber expansion joints (Figure B), Design Engineers had no choice but to incorporate expansion loops and anchors. Expansion joints enabled the Engineer to keep the riser straight, but potential failure became an issue. The failure of an expansion joint means not only loss of heating or cooling, but a good possibility of extensive water or steam damage. In order to periodically inspect the expansion joints, they must remain accessible and this is not always possible. Additional valving becomes a necessity for rapid shut down or maintenance. Valves are both expensive and slow to close to avoid water damage.

Both expansion joints and expansion loop systems require multiple anchor points which present the Design Engineer with yet another difficult task. The loads on the anchor pairs can be quite high when coupled with the forces to move the expansion loops or expansion joints plus expansion joint thrust. Large safety factors become advisable for both anchorage and structural supports.

Today's state of the art riser support design simplifies these problems by incorporating multiple spring mounts strategically placed to support the riser and allow expansion and contraction with small and easily calculable load changes. (Figure C)

The spring support systems can be designed to utilize a central isolated anchor which remains neutral during operation, or a totally free-floating system with spring support only. If a single anchor is used, it is located as close as possible to the middle of the riser to direct the pipe to expand away or contract towards the anchor point. By locating the anchor in the center of the riser the expansion and contraction at each end is cut in half. The anchor is designed to withstand the "worst case" forces generated when the water weight is removed for maintenance of equipment without the need to access and re-adjust the mountings.

Unanchored or totally free-floating systems are designed to expand or contract from the center as well, but control is far more difficult as branch off and end stiffnesses are difficult to calculate and installations must be closely watched to avoid accidental movement restrictions at branch offs. In addition, when water weight is removed for equipment maintenance, an alternate restraint method or individual mounting readjustment may be required.

Depending on the support structures strength, the number and location of spring mounts may vary from one set on every floor for maximum load distribution or they may be spaced at greater intervals. Isolated pipe guides should be used in most systems to maintain alignment of anchored or unanchored spring support systems. Risers can be butt welded when installed to assure integrity. They are easy to install and require no maintenance.

Most importantly, the load at each support point is known under all conditions, i.e., installed, empty, full and operating at both temperature extremes. An added benefit is that the riser is not only supported with minor load changes throughout its expansion and contraction, but it is also effectively isolated from the building as the springs provide low natural frequency support.

All negative aspects of the obsolete systems are avoided with properly designed spring supported riser systems.

Figure "D" shows an express 20 story hot water riser. The items known are:

- 1) Floor spacing: 12' 0" (3.7 m).
- 2) 12" (304 mm) Sch. 40 Pipe with insulation which weighs 109 lb/ft (162 kg/m). (Pipe and insulation weight = 60 lb/ft (89 kg/m) Water weight = 49 lb/ft (73 kg/m). Piping data for sizes through 24" (608mm) diameter are shown on Mason Data Sheet DS-500.)
- 3) Installed temperature = 70°F(21°C).
- 4) Operating temperature = 160°F(71°C).

### STEP 1) CALCULATE EXPANSION COEFFICIENT:

$$\Delta T = 160^{\circ}\text{F}(71^{\circ}\text{C}) - 70^{\circ}\text{F}(21^{\circ}\text{C}) = 90^{\circ}\text{F}(50^{\circ}\text{C}) \text{ Decrease}$$

Standard carbon steel expansion of 0.8"/100ft/100°F(20mm/30.5m/37°C) results in an expansion coefficient = 0.0072 in/ft(0.6mm/m)

**We will use the mount selection for the 19th floor to establish the method required for selections for the 15th, 5th and 1st floors:**

### STEP 2) DETERMINE THE INITIAL LOAD (IL):

The mountings on the 19th floor will support the piping from the 15th floor to the 20th floor: 60 ft (18.34m) x 109 lb/ft (162 kg/m) = 6,540 lb (2966 kg) ÷ 2 mounts = 3,270 lb (1483 kg)/each mounting

### STEP 3) DETERMINE THE EXPANSION (E) ON 19TH FLOOR:

The mountings are located 108 ft (33 m) above the anchor. (Length x expansion coefficient = expansion)  
108 ft (33 m) x 0.0072 in/ft (0.6 mm/m) = 0.777" (19.74 mm).

### STEP 4) SELECT THE MOUNTINGS REQUIRED:

The required capacity is 3,270 lb (1483 kg) and we know that the spring will lose approximately 3/4" (19 mm) deflection due to thermal growth, we select mount type SLFH-189 with a rated capacity of 4,900 lb (2223 kg) and a spring rate (K) of 915 lb/in (16340 kg/m) (Standard spring data are shown on Mason Data Sheets SLF-200-3 and DS-208 found in the spring mounts section of our catalog.)

### STEP 5) DETERMINE INITIAL DEFLECTION (ID): (IL÷K) 3,270 lb (1483 kg) ÷ 915 lb/in (16340 kg/m) = 3.574" (90.78 mm).

### STEP 6) DETERMINE FINAL DEFLECTION (FD): (ID±E) 3.574" (90.78 mm) - 0.777" (19.74 mm) = 2.8" (71.12 mm).

### STEP 7) DETERMINE FINAL LOAD (FL): (FDxK) 2.8" (71.12 mm) X 915 lb/in (16340 kg/m) = 2,562 lb (1162 kg).

### STEP 8) DETERMINE CHANGE IN LOAD (ΔL): (IL-FL) 3,270 lb (1483 kg) - 2562 lb (1162 kg) = 708 lb (321 kg). ↓

From the above calculations we generate the following table:

#### FOR THE 19TH FLOOR: MOUNT SELECTION: SLFH-189

IL: 3,270 lb (1483 kg)	ID: 3.574" (90.78 mm)	-E: 0.777" (19.72 mm)	FD: 2.8" (71.12 mm)	FL: 2,562 lb (1162 kg)	ΔL: 708 lb. ↓ (321 kg)
---------------------------	--------------------------	--------------------------	------------------------	---------------------------	---------------------------

**note:** Maintaining a consistent sign convention is important. This example is for an expanding riser and we use the following convention:

- A) Mountings above the anchor lose deflection and load carrying capacity, therefore, we use -E and ΔL ↓.
  - B) Mountings below the anchor gain deflection and load carrying capacity, therefore, we use +E and ΔL.
- The opposite is true for contracting risers such as chilled water, etc.

We perform calculation steps 2-8 for the 15th, 5th and 1st floors as tabled below:

#### FOR THE 15TH FLOOR:

**MOUNT SELECTION: SLFH-136**  
(CAPACITY = 4500 lb (2041 kg)  
K = 1370 lb/in (24465 kg/m))

IL: 3,270 lb (2041 kg)	FD: 1.96" (49.78 mm)
ID: 2.387" (60.63 mm)	FL: 2681 lb (1216 kg)
-E: 0.431" (10.95 mm)	ΔL: 589 lb ↓ (267 kg)

#### FOR THE 5TH FLOOR:

**MOUNT SELECTION: SLFH-136**  
(CAPACITY = 4500 lb (2041 kg)  
K = 1370 lb/in (24465 kg/m))

IL: 3,270 lb (2041 kg)	FD: 2.817" (71.55 mm)
ID: 2.387" (60.63 mm)	FL: 3859 lb (1750 kg)
+E: 0.431" (10.95 mm)	ΔL: 589 lb (267 kg)

#### FOR THE 1ST FLOOR:

**MOUNT SELECTION: SLFH-189**  
(CAPACITY = 4900 lb (2223 kg)  
K = 915 lb/in (16340 kg/m))

IL: 3,270 lb (2041 kg)	FD: 4.35" (110.49 mm)
ID: 3.574" (90.78 mm)	FL: 3980 lb (1805 kg)
+E: 0.777" (19.74 mm)	ΔL: 710 lb (322 kg)

### STEP 9) CALCULATE FORCES AT 10TH FLOOR ANCHOR:

The best way to gain insight to the various anchor loading conditions for this type of riser support is to examine the installation sequence: The lower elbow of the riser is temporarily supported and the pipe is constructed upward, continuously welded and guided. The temporary support in this example must be capable of supporting the empty pipe weight (60 lb/ft (89 kg/m) x 240 ft (73 m) = 14,400 lb (6532 kg)). When this is completed, the anchor is installed at the mid point of the riser. The various spring mounts are then positioned at the locations dictated and precompressed to the "initial deflection" to resist the anticipated load when water is added to the system. (Figure E) When the precompression is completed, and the riser is insulated, the sum of the spring force minus the steel pipe weight is translated to the anchor point and the temporary support removed. The anchor must be designed to withstand this up-lift force (weight of the water to be added to the pipe) as it represents the largest imposed load. **(Condition 1)**

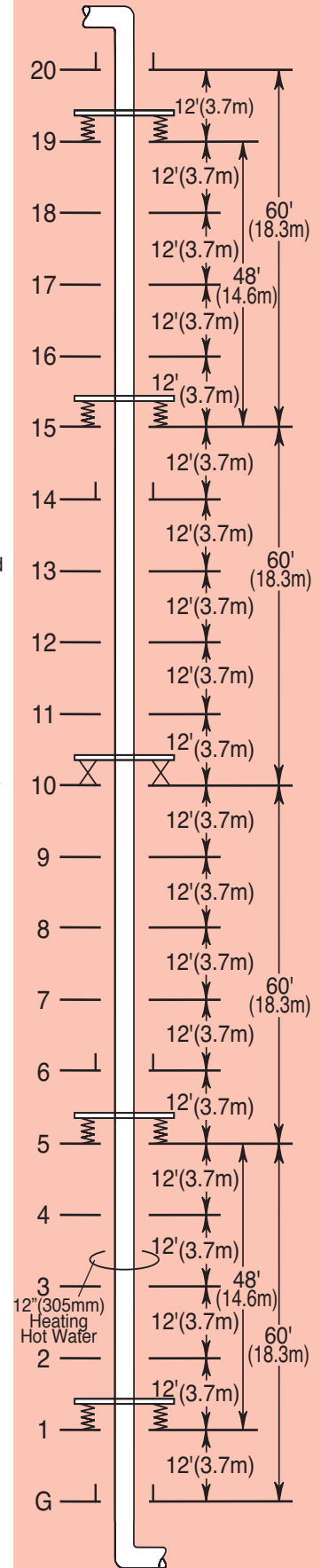

FIGURE D

The riser is then filled and the spring forces pushing up and the water and pipe weight pushing down negate each other causing the anchor point to become neutral at approximately zero load. **(Condition 2)** If we have an expanding riser and the system is brought up to operating temperature, the spring mounts above the anchor point will lose deflection resulting in a force down at the anchor and the spring mounts below the anchor point will gain deflection resulting in a force up at the anchor. The system is balanced so the load at the anchor remains zero and the riser weight is still distributed at the spring locations. **(Condition 3)**

**CONDITION 1: ANCHOR LOADINGS AFTER SPRING ADJUSTMENT/RISER DRY:**

$$\begin{aligned} \text{Total Riser Weight} - \text{Insulated Steel Pipe Weight} &= \text{Water Weight} \\ (\sum IL \times 2) - (240 \text{ ft (73.1 m)} \times 60 \text{ lb/ft (89 kg/m)}) &= \text{Water Weight} \\ 26,160 \text{ lb (11866 kg)} - 14,400 \text{ lb (6532 kg)} &= 11,760 \text{ lb (5334 kg) upward} \end{aligned}$$

**CONDITION 2: RISER FILLED.**

$$\begin{aligned} (\sum IL \times 2) - (\text{Total Riser Weight}) &= \text{Anchor Load.} \\ 26,160 \text{ lb (11866 kg)} - (240 \text{ ft (73.1 m)} \times 109 \text{ lb/ft (162 kg/m)}) &= \text{Anchor Load.} \\ 26,160 \text{ lb (11866 kg)} - 26,160 \text{ lb (11866 kg)} &= 0 \end{aligned}$$

**CONDITION 3: RISER @ OPERATING TEMPERATURE.**

$$\begin{aligned} 2 \times ((\sum \Delta L) - (\sum \Delta L \downarrow)) &= \text{Anchor Load.} \\ 2 \times ((589 \text{ lb (267 kg)} + 710 \text{ lb (322 kg))) - (589 \text{ lb (267 kg)} + 708 \text{ lb (322 kg)))} &= 4 \text{ lb (1.8 kg)} \end{aligned}$$

The system will revert to **CONDITION 1** when the riser is drained for maintenance of HVAC equipment.

**STEP 10) SELECT ANCHORS AND PIPE GUIDES:**

Worst case Anchor Loading is 11,760 lb (5334 kg) as shown in Condition 1 above. We select a pair of ADA-350 Isolated Anchors with an anchoring capacity of 24,000 lb (10886 kg) as shown on Mason Data Sheet DS-510. Anchor capacities can be achieved by either welding or bolting the ADA to structural steel. Special base plates can be provided for concrete attachment using drill-in anchors if adequate area is available and loading permits.

Data Sheet DS-510 also describes Type VSG Vertical Sliding Guides as well. It lists pre-calculated sizes and selections for guide spacing in tabular form on the back of the Data Sheet. The table requires a pair of pipe guides to be located at each end of the riser and the maximum distance between guides must not exceed 72 ft (21.9 m) for a 12" (305 mm) diameter pipe. We select pairs of VSG-200 installed at the ground floor, 6th floor, 14th floor and 20th floor.

It is important that the guide remain engaged throughout the pipe travel and that vibration transmission is minimized. The VSG design provides a heavy duty Neoprene bushing to prevent steel to steel contact as well as three initial settings which are factory pre-set with a shear pin. The VSG can accept either 3 1/4" (83 mm) upward movement only or 3 1/4" (83 mm) downward movement only, or 1 5/8" (41 mm) upward or downward movement. (Figure F)

The pipe movement at the guide location is determined by multiplying the distance from the anchor to the guide by the expansion coefficient as indicated in the table below. On expanding Risers, VSG guides below the anchor require "downward" movement capability and guides above require "upward" capability. The opposite holds true for contracting Risers.

GUIDE LOCATION	DISTANCE FROM ANCHOR	MOVEMENT (DISTANCE x 0.0072)	MOVEMENT DIRECTION
G	120 ft (36.6 m)	0.864 in (21.95 mm)	Downward
6	48 ft (14.6 m)	0.346 in (8.79 mm)	Downward
14	48 ft (14.6 m)	0.346 in (8.79 mm)	Upward
20	120 ft (36.6 m)	0.864 in (21.95 mm)	Upward

All VSG guides in this example to be provided with 1 5/8" (41 mm) Upward or Downward movement settings.

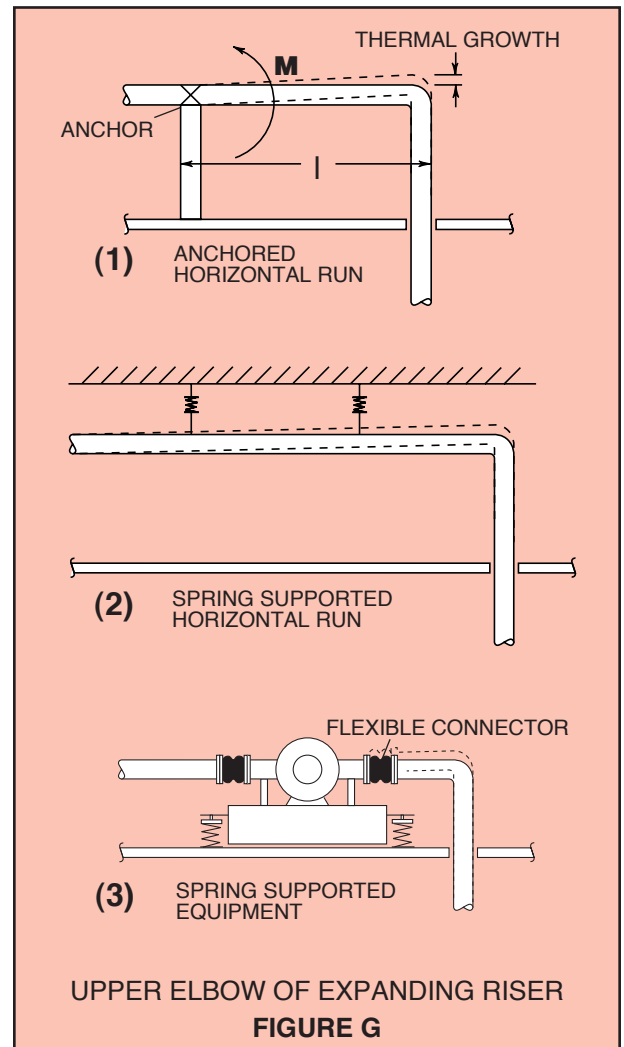
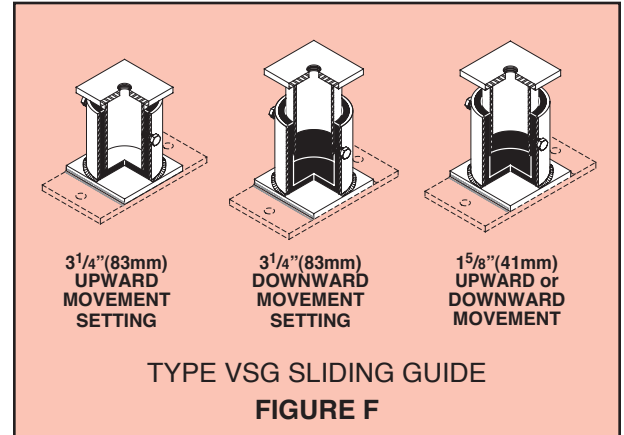
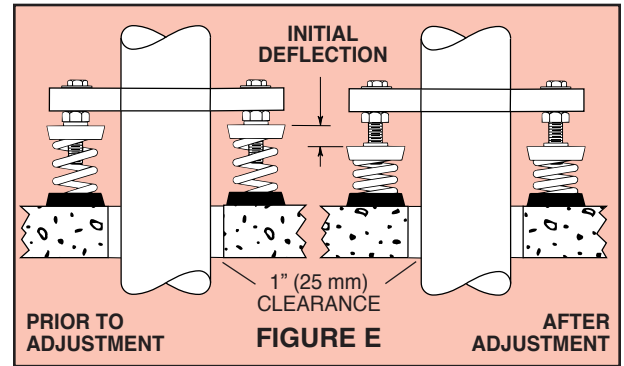

**STEP 11) INVESTIGATE END CONDITIONS AND  
BRANCH-OFF LOCATIONS:**

The stress generated by thermal pipe movement at upper & lower elbows and branch off locations is dependent on the horizontal piping configuration and the magnitude of movement at these transitions. The expected movement is easily calculated by multiplying the distance from the anchor to the transition by the expansion coefficient. The many variations in configurations of the horizontal pipe runs make it necessary to examine each case individually.

Pipe stress may be excessive when the horizontal run is anchored and there is bending from vertical pipe growth (Figure G(1)). The length between the anchor and the vertical pipe movement allows calculation of the bending moment and stress. This arrangement may be acceptable if the steel pipe stress does not exceed the allowable.

Spring hangers insure constant pipe support for unanchored horizontal pipe runs.(Figure G(2)) Vertical pipe movement can lift horizontal piping off non-spring supported clevis hardware transferring load elsewhere. The selection of horizontal pipe run spring hangers follows the same format as for vertical riser spring selection where low spring rate

(K) supports keep load changes to a minimum. Movements at equipment attachments must be checked to insure proper selection of flexible connectors.(Figure G(3))

**STEP 12) PIPE CLAMP AND BRACKET SELECTION:**

Hardware used to transfer spring mount and anchor loads to the pipe must be checked for shear and bending stresses. The use of standard pipe clamps or special brackets depends on the loadings.(Figure H)

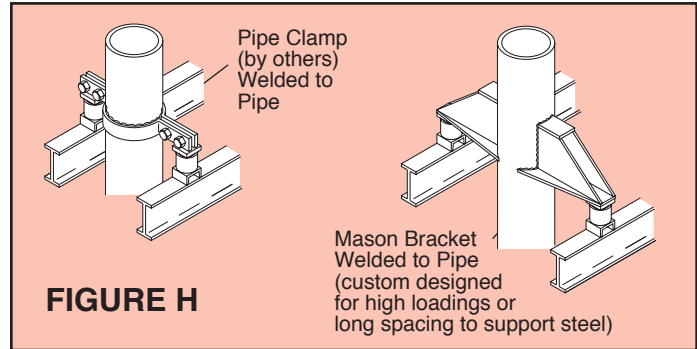

**DISCUSSION:**

The design example represents a simplified riser arrangement to show the concept and benefits of spring support. When pipe diameters increase or decrease throughout the riser length, design is more difficult to maintain neutral anchor loading at operating temperature. The anchor location, spring selection and placement may all

be varied to achieve minimal anchor loading.

The use of an isolated anchor is preferred to a free floating system as it allows accurate calculation of pipe movement and, by remaining neutral during operation, does not act as a significant vibration transmission point.

**RECOMMENDED RISER SUPPORT SPECIFICATION**

All vertical risers subjected to thermal expansion and/or contraction shall be supported by spring isolators and central anchors designed to insure loading within design limits at structural support points. The riser design must be prepared and submitted for approval by the same isolation vendor supplying the HVAC mechanical equipment isolation and must include the initial load, initial deflection, change in deflection, final load and change in load at all spring support locations. In order to minimize load changes, the initial spring deflection must be at least 4 times the thermal movement. The submittal must also include anchor loads when installed, cold filled, and at operating temperature. Include calculated pipe stress at end conditions and branch off locations as well as installation

instruction. The submittal must be stamped and signed by a licensed professional engineer in the employ of the vibration vendor for at least five years.

Proper provision shall be made for seismic protection in seismic zones.

The support spring mounts shall be Type SLF, anchors Type ADA, telescoping guides Type VSG, all as manufactured by Mason Industries, Inc.

The isolation vendor shall provide and design all brackets at riser spring and anchor locations where standard clamps lack capacity or do not fit. The contractor must install and adjust all isolators under the supervision of the designing isolation vendor or his representative.

